

S P E C F I L E

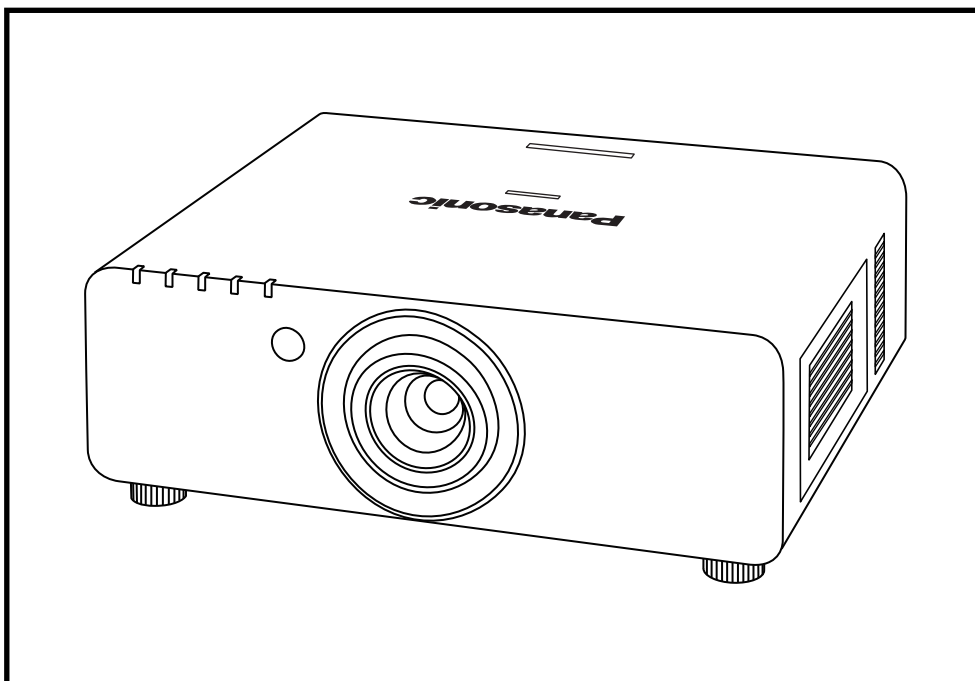

The PT-DZ6700L is not equipped with a lens.

Product Number : **PT-DZ6700/DZ6700L**

Product Name : DLP™ Projectors

Specifications

Main Unit

Power supply:	North America:	120 V AC, 50/60 Hz
	Europe:	220–240 V AC, 50/60 Hz
Power consumption:	North America:	820 W (880 VA) (Standby mode eco* ¹ : 0.2 W, Standby mode normal: 8 W. Both with fan stopped.)
	Europe:	800 W (960 VA) (Standby mode eco* ¹ : 0.3 W, Standby mode normal: 9 W. Both with fan stopped.)
DLP™ chip:	Panel size:	0.67" diagonal (16:10 aspect ratio)
	Display method:	DLP™ chip x 1, DLP™ system
	Pixels:	2,304,000 (1,920 x 1,200) x 1, total of 2,304,000 pixels
Lens:	PT-DZ6700:	Powered zoom/focus lenses (1.8–2.4:1), F 1.7–2.0, f 26.8–35.7 mm
	PT-DZ6700L:	Optional poweredzoom/focus lenses
Lamp:		300 W UHM lamps (x 2) (dual lamp system)
Screen size:		50–600 inches (50–200 inches with the ET-DLE055), 16:10 aspect ratio
Brightness* ² :		6,000 lumens (dual lamp, high power mode)
Center-to-corner uniformity* ² :		90%
Contrast* ² :		2,000:1 (full on/full off, contrast mode: high, brightness: 3,000 lumens) 1,000:1 (full on/full off, contrast mode: normal)
Resolution:		1,920 x 1,200 pixels
Scanning frequency:	RGB/DVI-D:	Horizontal: 15–91 kHz, Vertical: 50–85 Hz, Dot clock: 162 MHz or lower
	YPbPr (YCbCr):	525i (480i): fH 15.75 kHz; fV 60 Hz, 625i (576i): fH 15.63 kHz; fV 50 Hz, 525p (480p): fH 31.50 kHz; fV 60 Hz, 625p (576p): fH 31.25 kHz; fV 50 Hz, 750 (720)/60p: fH 45.00 kHz; fV 60 Hz, 750 (720)/50p: fH 37.50 kHz; fV 50 Hz, 1035/60i: fH 33.75 kHz; fV 60 Hz, 1125 (1080)/60i: fH 33.75 kHz; fV 60 Hz, 1125 (1080)/50i: fH 28.13 kHz; fV 50 Hz, 1080/25p: fH 28.13 kHz; fV 25 Hz, 1080/24p: fH 27.00 kHz; fV 24 Hz, 1080/24sF: fH 27.00 kHz; fV 48 Hz, 1080/30p: fH 33.75 kHz; fV 30 Hz, 1080/60p: fH 67.50 kHz; fV 60 Hz, 1080/50p: fH 56.25 kHz; fV 50 Hz
	S-Video/Video:	Horizontal: 15.75/15.63 kHz, Vertical: 50/60 Hz, (NTSC, NTSC4.43, PAL, PAL60, PAL-N, PAL-M, SECAM)
Optical axis shift:		Vertical: +50% (powered), horizontal: ±10% (powered)
Keystone correction range:		Vertical: ±40° (±30° with the ET-DLE055)
Installation:		Ceiling/floor, front/rear
Terminals* ³ :	DVI-D IN:	DVI-D 24-pin x 1, DVI 1.0 compliant, HDCP compatible, for single link only 480p, 576p, 720/60p, 720/50p, 1080/60i, 1080/50i, 1080/24p, 1080/24sF, 1080/25p, 1080/30p, 1080/60p, 1080/50p, VGA (640 x 480)–WUXGA* ⁴ (1,920 x 1,200), compatible with non-interlaced signals only, dot clock: 25–162 MHz
	RGB 1 IN:	BNC x 5
	R, G, B:	R: 0.7 Vp-p, 75 ohms, G: 0.7 Vp-p (G: 1.0 Vp-p for sync on G), 75 ohms, B: 0.7 Vp-p, 75 ohms
	Y, Pb, Pr:	HD/VD, SYNC: High impedance, TTL (positive/negative), 75 ohms Y: 1.0 Vp-p (including sync signal), Pb/Pr: 0.7 Vp-p, 75 ohms NOTE: HD/SYNC, and VD terminals do not accept tri-level sync signals.
	RGB 2 IN:	D-sub HD 15-pin x 1
	R, G, B:	R: 0.7 Vp-p, 75 ohms, G: 0.7 Vp-p (G: 1.0 Vp-p for sync on G), 75 ohms, B: 0.7 Vp-p, 75 ohms
	Y, Pb, Pr:	HD/VD, SYNC: High impedance, TTL (positive/negative), 75 ohms NOTE: HD/SYNC, and VD terminals do not accept tri-level sync signals. Y: 1.0 Vp-p (including sync signal), Pb/Pr: 0.7 Vp-p, 75 ohms

VIDEO IN:	BNC x 1, 1.0 Vp-p, 75 ohms
S-VIDEO IN:	Mini DIN 4-pin x 1, Y: 1.0 Vp-p, C: 0.286 Vp-p, 75 ohms
SERIAL IN:	D-sub 9-pin x 1 (RS-232C compliant) for external controller
SERIAL OUT:	D-sub 9-pin x 1 for link control
REMOTE 1 IN:	M3 jack x 1 for wired remote control
REMOTE 1 OUT:	M3 jack x 1 for link control
REMOTE 2 IN:	D-sub 9-pin x 1 for external control (parallel)
LAN:	RJ-45 x 1 for network connection, 10Base-T/100Base-TX, compliant with PLink™
Power cord length:	3.0 m (9'10")
Cabinet materials:	Molded plastic
Dimensions (W x H x D):	PT-DZ6700: 498 mm x 175 mm*5 x 440 mm*6 (19-19/32" x 6-7/8" *5 x 17-5/16" *6) (with supplied lens)
	PT-DZ6700L: 498 mm x 175 mm*5 x 432 mm (19-19/32" x 6-7/8" *5 x 17") (without lens)
Weight:	PT-DZ6700: Approx. 16.0 kg (35.3 lbs)(with supplied lens)
	PT-DZ6700L: Approx. 15.2 kg (33.5 lbs)(without lens)
Operating temperature:	0°–45°C (32°–113°F)
Operating humidity:	20%–80% (no condensation)

Remote Control Unit

Power supply:	3 V DC (AA battery x 2)
Operation range*7:	Approx. 30 m (98'5") when operated from directly signal receptor
Dimensions (W x H x D):	51 x 176 x 23 mm (2" x 6-15/16" x 29/32")
Weight:	134 g (4.7 oz) (including batteries)

Supplied Accessories

- Power cord
- Wireless/wired remote control unit
- Batteries for remote control (x 2)
- Wire rope

Optional Accessories

Zoom lens (1.3–1.9:1)	ET-DLE150
Zoom lens (2.3–3.6:1)	ET-DLE250
Zoom lens (3.6–5.4:1)	ET-DLE350
Zoom lens (5.4–8.6:1)	ET-DLE450
Fixed-focus lens (0.8:1)	ET-DLE055
Ceiling mount bracket:	ET-PKD56H (for high ceilings) ET-PKD55S (for low ceilings)

Weights and dimensions shown are approximate. Specifications subject to change without notice.

- *1 In Standby mode eco, LAN-based network functions such as the standby ON function will not operate.
- *2 Measurement, measuring conditions, and method of notation all comply with ISO 21118 international standards.
- *3 The HD/SYNC and VD inputs do not accept the tri-level sync signal.
- *4 WUXGA resolution is supported only when the signals are compliant with VESA CVT-RB (Coordinated Video Timing-Reduced Blanking).
- *5 With legs at shortest position.
- *6 Including the supplied lens.
- *7 Operation range differs depending on environments.

Dimensions

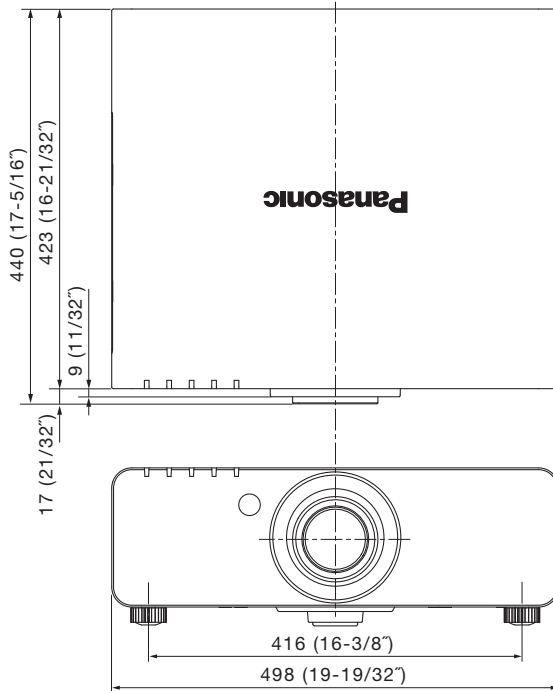

unit : mm (inch)

NOTE: This illustration is not drawn to scale.
The illustration shows the PT-DZ6700.

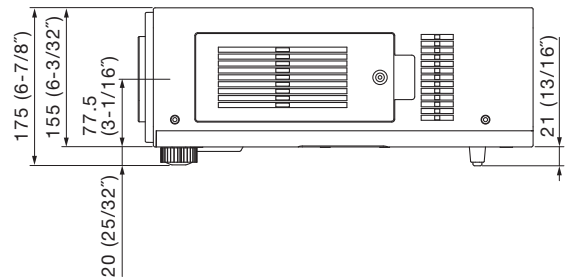

Terminals

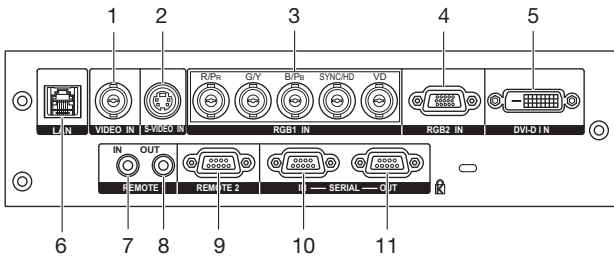

- | | |
|-----------------|-------------------|
| 1 Video input | 7 Remote 1 input |
| 2 S-Video input | 8 Remote 1 output |
| 3 RGB 1 input | 9 Remote 2 input |
| 4 RGB 2 Input | 10 Serial input |
| 5 DVI-D input | 11 Serial output |
| 6 LAN connector | |

Standard setting-up position (when installed using the ET-PKD56H)

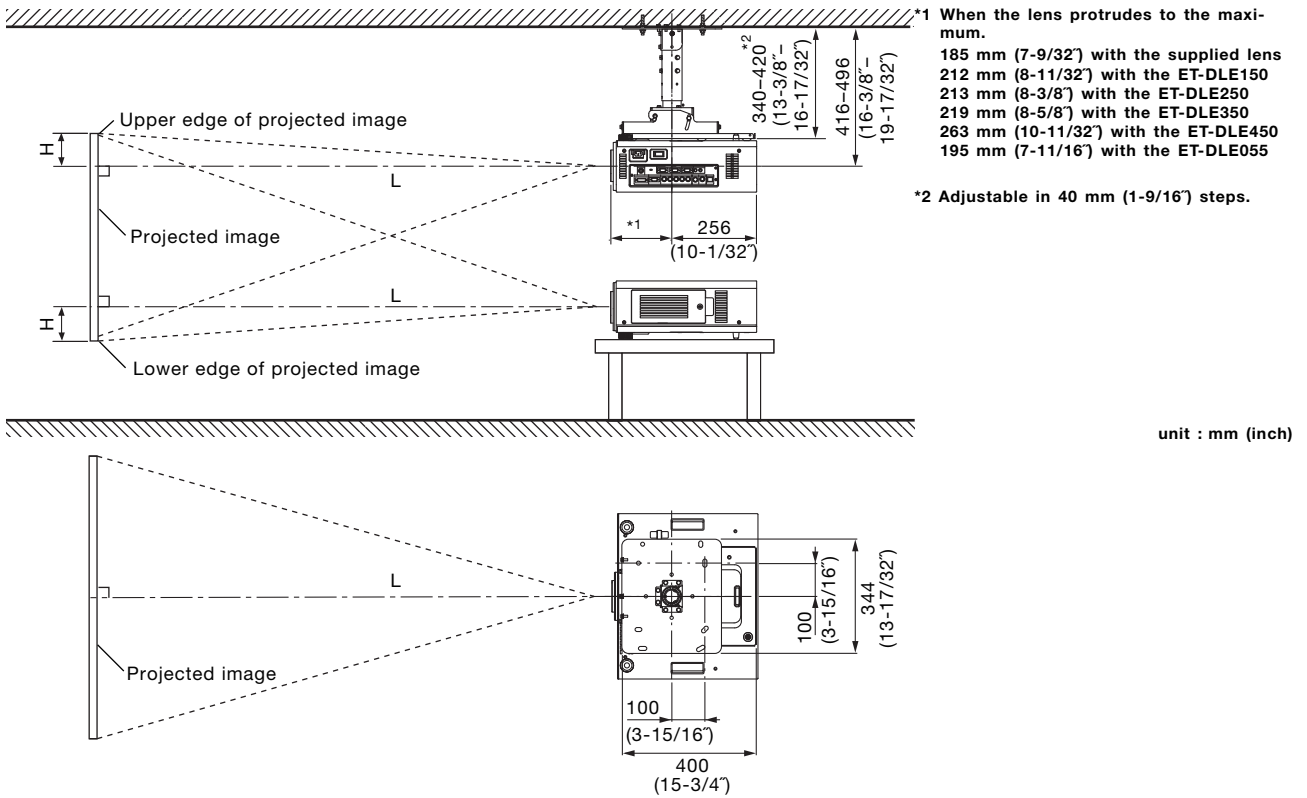

CAUTION

The ET-DLE055 has a fixed short-focus lens. Therefore, the lens shift function provided in the main unit cannot be used.
 If the lens shift function is used, the corners of images may not be displayed or images may remain out of focus in some cases.

Projection distance for 16:10 aspect ratio screen

Unit: millimeters

Screen size (inch, diagonal)	Distance to screen (L)										Height from the edge of screen to center of lens (H)		
	Zoom										Fixed-focus	Zoom lenses	Fixed-focus lens*
	ET-DLE150 Zoom lens		Supplied lens		ET-DLE250 Zoom lens		ET-DLE350 Zoom lens		ET-DLE450 Zoom lens		ET-DLE055 Fixed-focus lens		
min.	max.	min.	max.	min.	max.	min.	max.	min.	max.				
50	1,376	2,013	1,901	2,571	2,418	3,865	3,802	5,815	5,659	9,123	828	0 – 337	337
60	1,662	2,426	2,296	3,100	2,917	4,654	4,589	7,004	6,851	11,008	1,003	0 – 404	404
70	1,948	2,838	2,691	3,629	3,417	5,443	5,377	8,194	8,043	12,892	1,178	0 – 471	471
80	2,234	3,251	3,086	4,158	3,916	6,232	6,164	9,384	9,235	14,777	1,353	0 – 538	538
90	2,520	3,663	3,481	4,687	4,416	7,021	6,951	10,574	10,427	16,661	1,528	0 – 606	606
100	2,806	4,076	3,876	5,215	4,915	7,810	7,739	11,764	11,619	18,546	1,703	0 – 673	673
120	3,378	4,901	4,666	6,273	5,914	9,388	9,314	14,143	14,003	22,315	2,053	0 – 808	808
150	4,236	6,139	5,851	7,860	7,413	11,754	11,676	17,713	17,579	27,968	2,578	0 – 1010	1010
200	5,666	8,202	7,827	10,504	9,910	15,699	15,613	23,662	23,539	37,391	3,454	0 – 1,346	1,346
250	7,096	10,264	9,802	13,149	12,408	19,643	19,550	29,611	29,499	46,813	–	0 – 1,683	–
300	8,526	12,327	11,777	15,793	14,905	23,588	23,487	35,560	35,460	56,236	–	0 – 2,019	–
400	11,386	16,453	15,728	21,082	19,900	31,477	31,361	47,458	47,380	75,081	–	0 – 2,692	–
500	14,245	20,579	19,679	26,371	24,895	39,366	39,235	59,356	59,300	93,926	–	0 – 3,365	–
600	17,105	24,704	23,629	31,660	29,890	47,255	47,109	71,255	71,221	112,771	–	0 – 4,039	–

Unit: feet

Screen size (inch, diagonal)	Distance to screen (L)										Height from the edge of screen to center of lens (H)		
	Zoom										Fixed-focus	Zoom lenses	Fixed-focus lens*
	ET-DLE150 Zoom lens		Supplied lens		ET-DLE250 Zoom lens		ET-DLE350 Zoom lens		ET-DLE450 Zoom lens		ET-DLE055 Fixed-focus lens		
min.	max.	min.	max.	min.	max.	min.	max.	min.	max.				
50	4.6	6.7	6.3	8.5	8.0	12.7	12.5	19.1	18.6	30.0	2.7	0.0 – 1.1	1.1
60	5.5	8.0	7.6	10.2	9.6	15.3	15.1	23.0	22.5	36.2	3.3	0.0 – 1.4	1.4
70	6.4	9.4	8.9	12.0	11.3	17.9	17.7	26.9	26.4	42.3	3.9	0.0 – 1.6	1.6
80	7.4	10.7	10.2	13.7	12.9	20.5	20.3	30.8	30.3	48.5	4.5	0.0 – 1.8	1.8
90	8.3	12.1	11.5	15.4	14.5	23.1	22.9	34.7	34.3	54.7	5.1	0.0 – 2.0	2.0
100	9.3	13.4	12.8	17.2	16.2	25.7	25.4	38.6	38.2	60.9	5.6	0.0 – 2.3	2.3
120	11.1	16.1	15.4	20.6	19.5	30.9	30.6	46.5	46.0	73.3	6.8	0.0 – 2.7	2.7
150	13.9	20.2	19.2	25.8	24.4	38.6	38.4	58.2	57.7	91.8	8.5	0.0 – 3.4	3.4
200	18.6	27.0	25.7	34.5	32.6	51.6	51.3	77.7	77.3	122.7	11.4	0.0 – 4.5	4.5
250	23.3	33.7	32.2	43.2	40.8	64.5	64.2	97.2	96.8	153.6	–	0.0 – 5.6	–
300	28.0	40.5	38.7	51.9	49.0	77.4	77.1	116.7	116.4	184.6	–	0.0 – 6.7	–
400	37.4	54.0	51.7	69.2	65.3	103.3	102.9	155.8	155.5	246.4	–	0.0 – 8.9	–
500	46.8	67.6	64.6	86.6	81.7	129.2	128.8	194.8	194.6	308.2	–	0.0 – 11.1	–
600	56.2	81.1	77.6	103.9	98.1	155.1	154.6	233.8	233.7	370.0	–	0.0 – 13.3	–

- The value for L (distance to screen) varies slightly depending on the zoom lens characteristics.
- At the shortest projection distance, the zoom lens characteristics may cause slight image distortion.
- When vertical keystone correction is used, the image is corrected in the direction that reduces its projected size.
- The brightness varies depending on the zoom setting.

Projection distance for 16:9 aspect ratio screen

Unit: millimeters

Screen size (inch, diagonal)	Distance to screen (L)										Height from the edge of screen to center of lens (H)		
	Zoom										Fixed-focus	Zoom lenses	Fixed-focus lens*
	ET-DLE150 Zoom lens		Supplied lens		ET-DLE250 Zoom lens		ET-DLE350 Zoom lens		ET-DLE450 Zoom lens		ET-DLE055 Fixed-focus lens		
min.	max.	min.	max.	min.	max.	min.	max.	min.	max.				
50	1,416	2,070	1,956	2,645	2,487	3,975	3,911	5,980	5,824	9,385	852	-62 – 311	311
60	1,710	2,494	2,362	3,188	3,000	4,786	4,721	7,203	7,049	11,322	1,032	-75 – 374	374
70	2,004	2,919	2,768	3,732	3,514	5,597	5,530	8,426	8,275	13,259	1,212	-87 – 436	436
80	2,298	3,343	3,174	4,275	4,027	6,407	6,339	9,649	9,500	15,196	1,392	-100 – 498	498
90	2,591	3,767	3,580	4,819	4,541	7,218	7,148	10,872	10,725	17,133	1,572	-112 – 560	560
100	2,885	4,191	3,986	5,362	5,054	8,029	7,958	12,094	11,950	19,070	1,752	-125 – 623	623
120	3,473	5,039	4,798	6,450	6,081	9,651	9,576	14,540	14,400	22,944	2,112	-149 – 747	747
150	4,355	6,311	6,016	8,080	7,621	12,083	12,004	18,209	18,076	28,754	2,651	-187 – 934	934
200	5,825	8,431	8,046	10,798	10,188	16,137	16,051	24,323	24,202	38,439	3,551	-249 – 1,245	1,245
250	7,294	10,551	10,077	13,516	12,755	20,192	20,097	30,438	30,328	48,123	–	-311 – 1,557	–
300	8,764	12,671	12,107	16,234	15,322	24,246	24,144	36,552	36,454	57,808	–	-374 – 1,868	–
400	11,704	16,912	16,167	21,670	20,456	32,354	32,236	48,781	48,706	77,177	–	-498 – 2,491	–
500	14,643	21,152	20,228	27,106	25,590	40,462	40,329	61,010	60,957	96,546	–	-623 – 3,113	–
600	17,582	25,393	24,288	32,542	30,723	48,571	48,422	73,239	73,209	115,915	–	-747 – 3,736	–

Unit: feet

Screen size (inch, diagonal)	Distance to screen (L)										Height from the edge of screen to center of lens (H)		
	Zoom										Fixed-focus	Zoom lenses	Fixed-focus lens*
	ET-DLE150 Zoom lens		Supplied lens		ET-DLE250 Zoom lens		ET-DLE350 Zoom lens		ET-DLE450 Zoom lens		ET-DLE055 Fixed-focus lens		
min.	max.	min.	max.	min.	max.	min.	max.	min.	max.				
50	4.7	6.8	6.5	8.7	8.2	13.1	12.9	19.7	19.2	30.8	2.8	-0.2 – 1.0	1.0
60	5.7	8.2	7.8	10.5	9.9	15.8	15.5	23.7	23.2	37.2	3.4	-0.3 – 1.3	1.3
70	6.6	9.6	9.1	12.3	11.6	18.4	18.2	27.7	27.2	43.6	4.0	-0.3 – 1.5	1.5
80	7.6	11.0	10.5	14.1	13.3	21.1	20.8	31.7	31.2	49.9	4.6	-0.4 – 1.7	1.7
90	8.6	12.4	11.8	15.9	14.9	23.7	23.5	35.7	35.2	56.3	5.2	-0.4 – 1.9	1.9
100	9.5	13.8	13.1	17.6	16.6	26.4	26.2	39.7	39.3	62.6	5.8	-0.5 – 2.1	2.1
120	11.4	16.6	15.8	21.2	20.0	31.7	31.5	47.8	47.3	75.3	7.0	-0.5 – 2.5	2.5
150	14.3	20.8	19.8	26.6	25.1	39.7	39.4	59.8	59.4	94.4	8.7	-0.7 – 3.1	3.1
200	19.2	27.7	26.4	35.5	33.5	53.0	52.7	79.8	79.5	126.2	11.7	-0.9 – 4.1	4.1
250	24.0	34.7	33.1	44.4	41.9	66.3	66.0	99.9	99.6	157.9	–	-1.1 – 5.2	–
300	28.8	41.6	39.8	53.3	50.3	79.6	79.3	120.0	119.6	189.7	–	-1.3 – 6.2	–
400	38.4	55.5	53.1	71.1	67.2	106.2	105.8	160.1	159.8	253.3	–	-1.7 – 8.2	–
500	48.1	69.4	66.4	89.0	84.0	132.8	132.4	200.2	200.0	316.8	–	-2.1 – 10.3	–
600	57.7	83.4	79.7	106.8	100.8	159.4	158.9	240.3	240.2	380.3	–	-2.5 – 12.3	–

- The value for L (distance to screen) varies slightly depending on the zoom lens characteristics.
- At the shortest projection distance, the zoom lens characteristics may cause slight image distortion.
- When vertical keystone correction is used, the image is corrected in the direction that reduces its projected size.
- The brightness varies depending on the zoom setting.

Projection distance for 4:3 aspect ratio screen

Unit: millimeters

Screen size (inch, diagonal)	Distance to screen (L)										Height from the edge of screen to center of lens (H)		
	Zoom										Fixed-focus	Zoom lenses	Fixed-focus lens*
	ET-DLE150 Zoom lens		Supplied lens		ET-DLE250 Zoom lens		ET-DLE350 Zoom lens		ET-DLE450 Zoom lens		ET-DLE055 Fixed-focus lens		
min.	max.	min.	max.	min.	max.	min.	max.	min.	max.				
50	1,565	2,286	2,162	2,920	2,747	4,386	4,322	6,600	6,446	10,368	943	0 – 381	381
60	1,889	2,753	2,609	3,519	3,313	5,279	5,213	7,947	7,795	12,501	1,142	0 – 457	457
70	2,212	3,220	3,056	4,118	3,878	6,173	6,105	9,294	9,145	14,635	1,340	0 – 533	533
80	2,536	3,687	3,503	4,716	4,444	7,066	6,996	10,641	10,494	16,768	1,538	0 – 610	610
90	2,860	4,154	3,951	5,315	5,009	7,959	7,887	11,988	11,844	18,902	1,736	0 – 686	686
100	3,184	4,621	4,398	5,914	5,575	8,852	8,779	13,335	13,193	21,035	1,934	0 – 762	762
120	3,831	5,555	5,292	7,111	6,706	10,638	10,562	16,029	15,892	25,302	2,331	0 – 914	914
150	4,802	6,956	6,634	8,908	8,402	13,317	13,236	20,070	19,941	31,702	2,925	0 – 1143	1143
200	6,421	9,291	8,870	11,901	11,229	17,783	17,693	26,805	26,688	42,369	3,916	0 – 1,524	1,524
250	8,040	11,627	11,107	14,895	14,057	22,248	22,150	33,540	33,435	53,036	–	0 – 1,905	–
300	9,659	13,962	13,343	17,889	16,884	26,714	26,607	40,275	40,183	63,703	–	0 – 2,286	–
400	12,896	18,633	17,815	23,876	22,539	35,645	35,521	53,744	53,678	85,037	–	0 – 3,048	–
500	16,134	23,303	22,288	29,864	28,194	44,576	44,435	67,214	67,172	106,371	–	0 – 3,810	–
600	19,372	27,974	26,760	35,851	33,848	53,507	53,349	80,684	80,667	127,705	–	0 – 4,572	–

Unit: feet

Screen size (inch, diagonal)	Distance to screen (L)										Height from the edge of screen to center of lens (H)		
	Zoom										Fixed-focus	Zoom lenses	Fixed-focus lens*
	ET-DLE150 Zoom lens		Supplied lens		ET-DLE250 Zoom lens		ET-DLE350 Zoom lens		ET-DLE450 Zoom lens		ET-DLE055 Fixed-focus lens		
min.	max.	min.	max.	min.	max.	min.	max.	min.	max.				
50	5.2	7.5	7.1	9.6	9.1	14.4	14.2	21.7	21.2	34.1	3.1	0.0 – 1.3	1.3
60	6.2	9.1	8.6	11.6	10.9	17.4	17.2	26.1	25.6	41.1	3.8	0.0 – 1.5	1.5
70	7.3	10.6	10.1	13.6	12.8	20.3	20.1	30.5	30.1	48.1	4.4	0.0 – 1.8	1.8
80	8.4	12.1	11.5	15.5	14.6	23.2	23.0	35.0	34.5	55.1	5.1	0.0 – 2.1	2.1
90	9.4	13.7	13.0	17.5	16.5	26.2	25.9	39.4	38.9	62.1	5.7	0.0 – 2.3	2.3
100	10.5	15.2	14.5	19.5	18.3	29.1	28.9	43.8	43.3	69.1	6.4	0.0 – 2.5	2.5
120	12.6	18.3	17.4	23.4	22.1	35.0	34.7	52.6	52.2	83.1	7.7	0.0 – 3.0	3.0
150	15.8	22.9	21.8	29.3	27.6	43.7	43.5	65.9	65.5	104.1	9.6	0.0 – 3.8	3.8
200	21.1	30.5	29.2	39.1	36.9	58.4	58.1	88.0	87.6	139.1	12.9	0.0 – 5.0	5.0
250	26.4	38.2	36.5	48.9	46.2	73.0	72.7	110.1	109.7	174.1	–	0.0 – 6.3	–
300	31.7	45.9	43.8	58.7	55.4	87.7	87.3	132.2	131.9	209.0	–	0.0 – 7.5	–
400	42.4	61.2	58.5	78.4	74.0	117.0	116.6	176.4	176.2	279.0	–	0.0 – 10.0	–
500	53.0	76.5	73.2	98.0	92.5	146.3	145.8	220.6	220.4	349.0	–	0.0 – 12.5	–
600	63.6	91.8	87.8	117.7	111.1	175.6	175.1	264.8	264.7	419.0	–	0.0 – 15.0	–

- The value for L (distance to screen) varies slightly depending on the zoom lens characteristics.
- At the shortest projection distance, the zoom lens characteristics may cause slight image distortion.
- When vertical keystone correction is used, the image is corrected in the direction that reduces its projected size.
- The brightness varies depending on the zoom setting.

Calculation of the projection distance

For a screen size different from the above, use the equation below to calculate the projection distance.

Aspect ratio 16:10

ET-DLE150	minimum	$L \text{ (mm)} = (\text{diagonal screen size in inches}) \times 28.6 - 54.0$
	maximum	$L \text{ (mm)} = (\text{diagonal screen size in inches}) \times 41.3 - 49.8$
Supplied lens	minimum	$L \text{ (mm)} = (\text{diagonal screen size in inches}) \times 39.5 - 74.5$
	maximum	$L \text{ (mm)} = (\text{diagonal screen size in inches}) \times 52.9 - 73.4$
ET-DLE250	minimum	$L \text{ (mm)} = (\text{diagonal screen size in inches}) \times 50.0 - 80.0$
	maximum	$L \text{ (mm)} = (\text{diagonal screen size in inches}) \times 78.9 - 79.2$
ET-DLE350	minimum	$L \text{ (mm)} = (\text{diagonal screen size in inches}) \times 78.7 - 135.1$
	maximum	$L \text{ (mm)} = (\text{diagonal screen size in inches}) \times 119.0 - 134.6$
ET-DLE450	minimum	$L \text{ (mm)} = (\text{diagonal screen size in inches}) \times 119.2 - 301.7$
	maximum	$L \text{ (mm)} = (\text{diagonal screen size in inches}) \times 188.5 - 299.1$
ET-DLE055	(fixed focus)	$L \text{ (mm)} = (\text{diagonal screen size in inches}) \times 17.5 - 47.6$

Aspect ratio 16:9

ET-DLE150	minimum	$L \text{ (mm)} = (\text{diagonal screen size in inches}) \times 29.4 - 54.0$
	maximum	$L \text{ (mm)} = (\text{diagonal screen size in inches}) \times 42.4 - 49.8$
Supplied lens	minimum	$L \text{ (mm)} = (\text{diagonal screen size in inches}) \times 40.6 - 74.5$
	maximum	$L \text{ (mm)} = (\text{diagonal screen size in inches}) \times 54.4 - 73.4$
ET-DLE250	minimum	$L \text{ (mm)} = (\text{diagonal screen size in inches}) \times 51.3 - 80.0$
	maximum	$L \text{ (mm)} = (\text{diagonal screen size in inches}) \times 81.1 - 79.2$
ET-DLE350	minimum	$L \text{ (mm)} = (\text{diagonal screen size in inches}) \times 80.9 - 135.1$
	maximum	$L \text{ (mm)} = (\text{diagonal screen size in inches}) \times 122.3 - 134.6$
ET-DLE450	minimum	$L \text{ (mm)} = (\text{diagonal screen size in inches}) \times 122.5 - 301.7$
	maximum	$L \text{ (mm)} = (\text{diagonal screen size in inches}) \times 193.7 - 299.1$
ET-DLE055	(fixed focus)	$L \text{ (mm)} = (\text{diagonal screen size in inches}) \times 18.0 - 47.6$

Aspect ratio 4:3

ET-DLE150	minimum	$L \text{ (mm)} = (\text{diagonal screen size in inches}) \times 32.4 - 54.0$
	maximum	$L \text{ (mm)} = (\text{diagonal screen size in inches}) \times 46.7 - 49.8$
Supplied lens	minimum	$L \text{ (mm)} = (\text{diagonal screen size in inches}) \times 44.7 - 74.5$
	maximum	$L \text{ (mm)} = (\text{diagonal screen size in inches}) \times 59.9 - 73.4$
ET-DLE250	minimum	$L \text{ (mm)} = (\text{diagonal screen size in inches}) \times 56.5 - 80.0$
	maximum	$L \text{ (mm)} = (\text{diagonal screen size in inches}) \times 89.3 - 79.2$
ET-DLE350	minimum	$L \text{ (mm)} = (\text{diagonal screen size in inches}) \times 89.1 - 135.1$
	maximum	$L \text{ (mm)} = (\text{diagonal screen size in inches}) \times 134.7 - 134.6$
ET-DLE450	minimum	$L \text{ (mm)} = (\text{diagonal screen size in inches}) \times 135.0 - 301.7$
	maximum	$L \text{ (mm)} = (\text{diagonal screen size in inches}) \times 213.3 - 299.1$
ET-DLE055	(fixed focus)	$L \text{ (mm)} = (\text{diagonal screen size in inches}) \times 19.8 - 47.6$

• Distances calculated with the above equations will include a slight error.

Shift range

Optical axis shift function allows to shift the position of a projected image as shown below.

• **Floor mount**

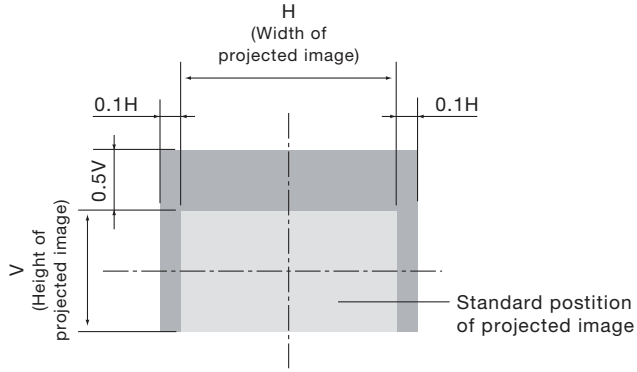

• **Ceiling mount**

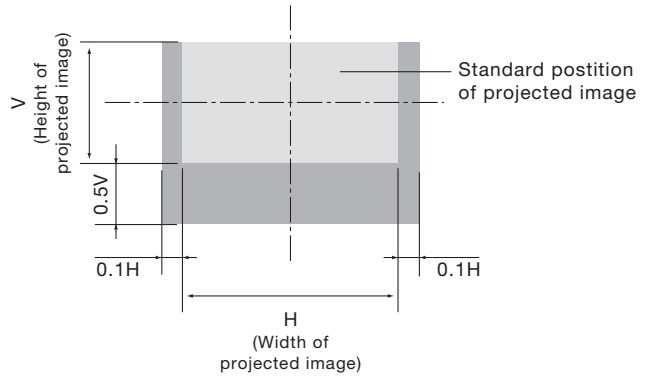

Installable angle

Install the projector at an angle within the range shown below.

• **Vertical direction**

The projector may be installed at a vertical angle of 360°.

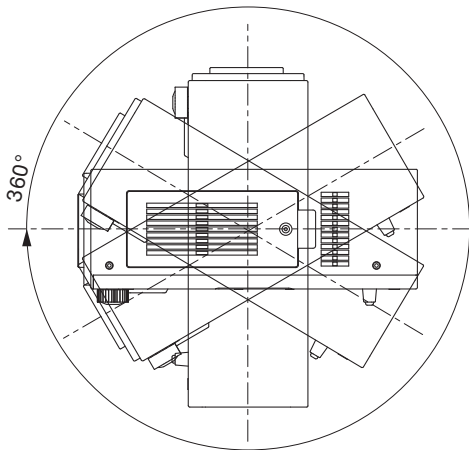

• **Horizontal direction**

The projector may be installed at a horizontal angle of ±10°.

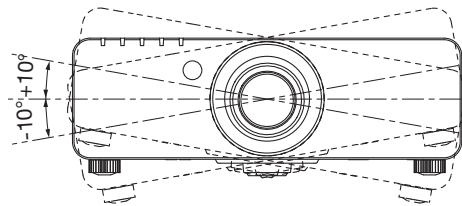

List of compatible signals

This projector supports RGB signals with horizontal frequencies of 15 to 91 kHz, vertical frequencies of 50 to 85 Hz and up to 162 MHz dot clock.

NOTE: The native resolution of this projector is 1,920 x 1,200 pixels. If the display resolution of the input signal is different from the native resolution, image compression or expansion will be used to convert the input signal to a level within the native resolution.

Display mode	Display resolution (dots) ¹	Scanning frequency H (kHz)	V (kHz)	Dot clock frequency (MHz)	Picture quality ²	Format
NTSC/NTSC4.43/PAL-M/PAL60	720 x 480i	15.7	59.9	–	A	VIDEO/S-VIDEO
PAL/PAL-N/SECAM	720 x 576i	15.6	50.0	–	A	
480i(525i)	720 x 480i	15.7	59.9	13.5	A	YPbPr /RGB
576i(625i)	720 x 576i	15.6	50.0	13.5	A	
480p(525p)	720 x 483	31.5	59.9	27.0	A	YPbPr /RGB/DVI
576p(625p)	720 x 576	31.3	50.0	27.0	A	
720/60p	1,280 x 720	45.0	60.0	74.3	A	
720/50p		37.5	50.0	74.3	A	
1080/60i	1,920 x 1,080i	33.8	60.0	74.3	AA	
1080/50i		28.1	50.0	74.3	AA	
1080/24p	1,920 x 1,080	27.0	24.0	74.3	AA	
1080/24sF	1,920 x 1,080i	27.0	24.0	74.3	AA	
1080/25p	1,920 x 1,080	28.1	50.0	74.3	AA	
1080/30p		33.8	60.0	74.3	AA	
1080/60p		67.5	60.0	148.5	AA	
1080/50p		56.3	50.0	148.5	AA	
VGA400	640 x 400	31.5	70.1	25.2	A	RGB/DVI
		37.9	85.1	31.5	A	
VGA480	640 x 480	31.5	59.9	25.2	A	
		35.0	66.7	30.2	A	
		37.9	72.8	31.5	A	
		37.5	75.0	31.5	A	
		43.3	85.0	36.0	A	
SVGA	800 x 600	35.2	56.3	36.0	A	
		37.9	60.3	40.0	A	
		48.1	72.2	50.0	A	
		46.9	75.0	49.5	A	
		53.7	85.1	56.3	A	
MAC16	832 x 624	49.7	74.6	57.3	A	
XGA	1,024 x 768	39.6	50.0	51.9	A	
		48.4	60.0	65.0	A	
		56.5	70.1	75.0	A	
		60.0	75.0	78.8	A	
		65.5	81.6	86.0	A	
		68.7	85.0	94.5	A	
		80.0	100.0	105.0	A	
		96.7	120.0	130.0	A	
MXGA	1,152 x 864	64.0	71.2	94.2	A	
		67.5	74.9	108.0	A	
		76.7	85.0	121.5	A	
MAC21	1,152 x 870	68.7	75.1	100.0	A	
1280 x 768	1,280 x 768	39.6	49.9	65.3	A	
		47.8	59.9	79.5	A	
1280 x 800	1,280 x 800	41.3	50.0	68.0	A	
		49.7	59.8	83.5	A	
MSXGA	1,280 x 960	60.0	60.0	108.0	A	
SXGA	1,280 x 1,024	64.0	60.0	108.0	A	
		80.0	75.0	135.0	A	
		91.1	85.0	157.5	A	
SXGA+	1,400 x 1,050	64.0	60.0	108.0	A	
		82.2	75.0	155.9	A	
WXGA+	1,440 x 900	55.9	59.9	106.5	A	
UXGA	1,600 x 1,200	75.0	60.0	162.0	A	
WSXGA+	1,680 x 1,050	65.3	60.0	146.3	A	
1920 x 1080	1,920 x 1,080	66.6	59.9	138.5	AA	
WUXGA ³	1,920 x 1,200	74.0	60.0	154.0	AA	

1. The “i” appearing after the resolution indicates an interlaced signal.

2. The following symbols are used to indicate picture quality.

AA Maximum picture quality can be obtained.

A Signals are converted by the image processing circuit before picture is projected.

3. WUXGA resolution is supported only when the signals are compliant with VESA CVT-RB (Coordinated Video Timing-Reduced Blanking).

Serial connector

The serial connector complies with RS-232C. To control the projector from a personal computer, commands must be input through communication software, based on the format and satisfying the communication conditions shown below.

Pin assignments and signal names

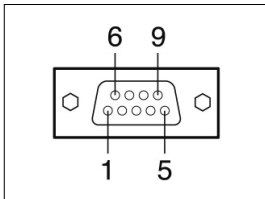

D-sub 9-pin (female)
Serial input

No.	Signal name	Description	No.	Signal name	Description
1	-	NC	6	-	NC
2	TXD	Send data	7	CTS	Connected internally
3	RXD	Receive data	8	RTS	Connected internally
4	-	Connected internally	9	-	NC
5	GND	Ground			

Pin assignments and signal names

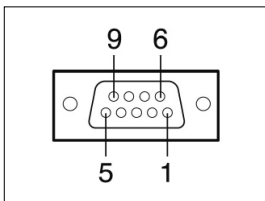

D-sub 9-pin (male)
Serial output

No.	Signal name	Description	No.	Signal name	Description
1	-	NC	6	-	NC
2	RXD	Receive data	7	RTS	Connected internally
3	TXD	Send data	8	CTS	Connected internally
4	-	Connected internally	9	-	NC
5	GND	Ground			

Communication conditions (factory setting)

Signal level	RS-232C-compliant
Synchronization method	Start-stop synchronization
Baud rate	9,600 bps
Parity	None
Character length	8 bits
Stop bit	1 bit
X parameter	None
S parameter	None

Basic format

Transmission from the computer begins with STX, then the ID, command, parameter, and ETX are sent in this order. Add parameters according to the details of control.

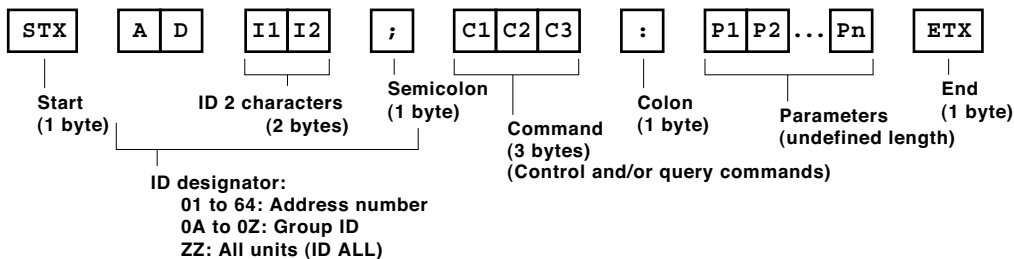

CAUTION

- It may not be possible to send or receive commands for about 10 to 60 seconds when the lamp is first turned on. If this occurs, wait for 60 seconds, then try sending or receiving again.
- When sending multiple commands, be sure to wait for at least 0.5 second after receiving a response from the projector before sending the next command.
- Additional time is sometimes required for response due to processing inside the projector. Set the time-out period for command response to 10 seconds or more.

Cable specifications

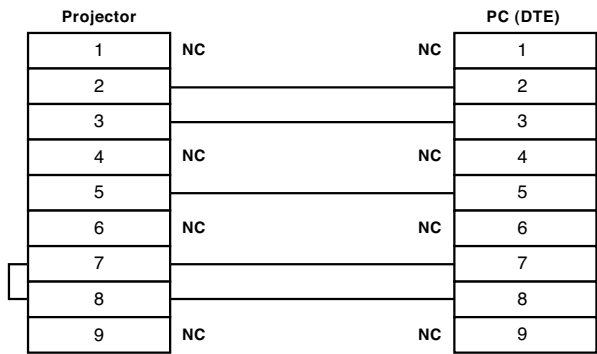

Control commands

Command : Parameter	Function		Callback
PON	POWER (STANDBY)	Standby power on	PON
POF		Standby power off	POF
IIS:DVI	INPUT SELECT	DVI	IIS:DVI
IIS:RG1		RGB 1	IIS:RG1
IIS:RG2		RGB 2	IIS:RG2
IIS:VID		Video	IIS:VID
IIS:SVD		S-VideoAUX	IIS:SVD
LPM:0	LAMP SELECT	Dual (two lamps)	LPM:0
LPM:1		Lamp 1	LPM:1
LPM:2		Lamp 2	LPM:2
LPM:3		Single lamp	LPM:3
OSH:0	SHUTTER	Shutter on	OSH:0
OSH:1		Shutter off	OSH:1
OFZ:0	FREEZE	Off	OFZ:0
OFZ:1		On	OFZ:1
OAS	AUTO SETUP		OAS
VPM:NAT	PICTURE MODE	Natural	VPM:NAT
VPM:STD		Standard	VPM:STD
VPM:DYN		Dynamic	VPM:DYN
VPM:CIN		Cinema	VPM:CIN
VPM:GRA		Graphic	VPM:GRA
VXX:DLVI0=+00000	SYSTEM DAYLIGHT VIEW 2	Off	VXX:DLVI0=+00000
VXX:DLVI0=+00001		1	VXX:DLVI0=+00001
VXX:DLVI0=+00002		2	VXX:DLVI0=+00002
VXX:DLVI0=+00003		3	VXX:DLVI0=+00003
OTE:1	COLOR TEMPERATURE	Middle	OTE:1
OTE:2		High	OTE:2
OTE:4		User	OTE:4
OTE:10		Default	OTE:10
TSD:y1y2y3y4m1m2d1d2w	DATE	Date setting	TSD:y1y2y3y4m1m2d1d2w
TST:h1h2m1m2s1s2	TIME	Time setting	TST:h1h2m1m2s1s2
OOS:0	ON SCREEN	On-screen display on	OOS:0
OOS:1		On-screen display off	OOS:1

* Do not send PON, POF, OSH, or OLP commands continuously in a short period of time. Doing so may burst the lamp or shorten the lamp replacement cycle.

* When a command that cannot be executed during standby mode is sent, the projector will send an ER401 command in reply.

Status asking commands

Command:Parameter	Function	Callback	Description		
QPW	Main power status	000	Standby (Off)		
		001	On		
QSH	Shutter function status	0	Off		
		1	On		
QFZ	Freeze function status	0	Off		
		1	On		
QIN	Input signal status	DVI	DVI		
		RG1	RGB 1		
		RG2	RGB 2		
		VID	Video		
		SVD	S-Video		
QOS	On-screen display status	0	Off		
		1	On		
QST	Projector run time	p1p2p3p4p5	00000h-99999h		
Q\$L:1	Lamp 1 run time	p1p2p3p4	0000h-9999h		
Q\$L:2	Lamp 2 run time	p1p2p3p4	0000h-9999h		
QSL	Lamp operation mode status	0	Dual		
		1	Single		
		2	Lamp 1		
		3	Lamp 2		
QLP	Lamp power mode status	0	High		
		1	Low		
		NAT	Natural		
		STD	Standard		
		DYN	dynamic		
QPM	Picture mode status	CIN	Cinema		
		GRA	Graphic		
		DLVI0=+00000	Off		
		DLVI0=+00001	1		
QVX:DLVI0	System daylight view status	DLVI0=+00002	2		
		DLVI0=+00003	3		
		QTM:0	Temperature status	p1p2p3p4/p5p6p7p8 ^(*)	p0 = Intake air
		QTM:1			p1 = Exhaust air
QTM:2	p2 = DLP™ chip				
QGD	Date setting status	y1y2y3y4m1m2d1d2w	yyyymmdd (day of week) ^(**)		
QGT	Time setting status	h1h2m1m2s1s2	hhmmss ^(***)		

*1 p1p2p3p4: Celsius (°C), p5p6p7p8: Fahrenheit (°F)
 *2 Day of week: Monday = 1, Tuesday = 2, ... Sunday = 7
 *3 Set the date and time to UTC (universal time coordinated).

Command example

To set the on-screen display off, send the command as shown below.

STX ADZZ ; OOS : 30 ETX
 | | | | |
 Start ID Address Command Parameter End

NOTE: When sending commands without parameters, a colon (:) is not necessary.

Notes on Projector Placement and Operation

The projector uses a high-wattage lamp that becomes very hot during operation. Please observe the following precautions.

1. Never place objects on top of the projector while it is operating.
2. Make sure there is an unobstructed space of 500 mm or more around the projector's exhaust openings.
3. Do not stack projector units directly on top of one another. If two units must be stacked for back-up use in ordinary projection, use a method as shown below and provide ample space between the units to ensure that exhaust heat does not accumulate near the intake opening or around the units. Dual stacked projection is not recommended.
4. If the projector is placed in a box or enclosure, ensure the temperature of the air surrounding the projector is between 0°C/32°F and 40°C/104°F*. Also make sure the projector's intake and exhaust openings are not blocked. Take particular care to ensure that hot air from the exhaust openings is not sucked into the intake openings.

* Even when the ambient temperature near the intake opening is 40°C/104°F or lower, an accumulation of hot air inside the cabinet may cause the protective circuit to activate and shut down the projector. Please give ample consideration to the design with regard to ambient temperature conditions.

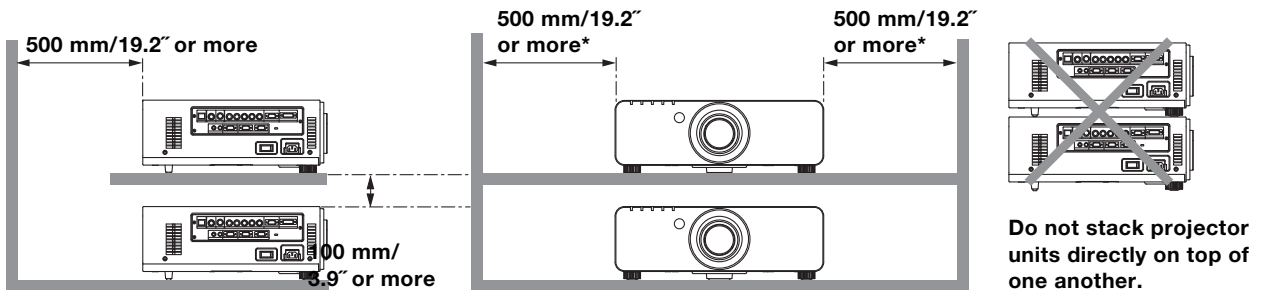

Direction of Air Intake and Exhaust

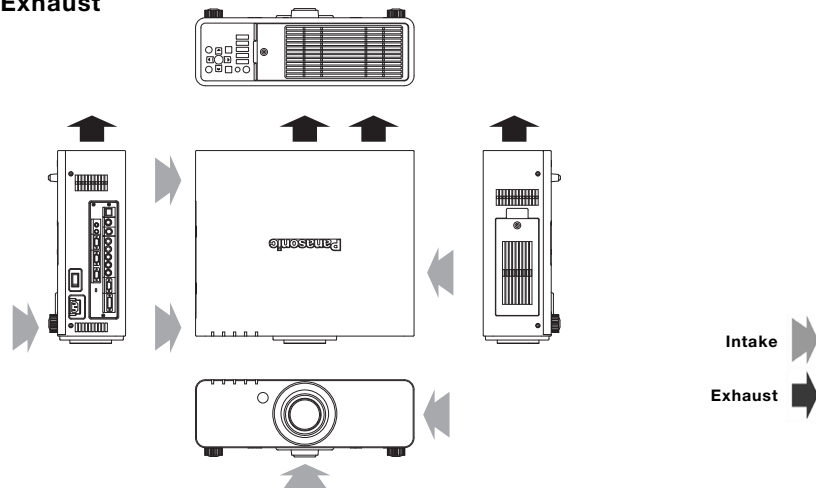

Operating the Projector Continuously

1. If the projector is to be operated continuously 24 hours a day, use the dual-lamp optical system's alternating lamp operation (lamp changer) function. The projector cannot be operated continuously 24 hours a day in dual-lamp mode. Allow a minimum of two hours per day of non-operation time.
2. The lamp replacement cycle duration becomes shorter if the projector is operated repeatedly for short periods.

DLP and the DLP logo are trademarks of Texas Instruments.
 PJLink is a registered trademark, or a trademark application has been filed, in Japan, the United States, and other countries and regions.
 All other trademarks are the property of their respective trademark owners.